



Standard or Automatic
Transmissions



Take Control
(of your Shift)!



CHEETAH E-SHIFT™

Part #70600

Turbo Action's All New *CHEETAH E-SHIFT Controller* will Take Control (of your Shift) no matter what type of transmission or shifter you own. The controller is digital and requires no rpm chips.

Standard transmission equipped vehicles can tie in the clutch pedal and shift light system for the ultimate control of shift points. After the final shift, the light will not come back on.

Automatic transmission equipped cars can use the *CHEETAH E-SHIFT Controller* for shifting the Turbo Action *CHEETAH E-SHIFT Electronic Valve Bodies*, shift lights and automated shift devices (Air, C02, Electric).

1535 Owens Road - Jacksonville, Florida 32218

Phone 904-741-4850 - FAX 904-741-4853

01/21/02

Caution! Caution!

Air/CO2 and Electric Shift Devices

You must set rpm

in the CHEETAH E-SHIFT Controller

before starting vehicle!

**Failure to do this could cause injury and
or property damage!**

Read Instructions Below

Testing Your Controller Using a Air/CO2 or Electric Shift Device

The CHEETAH E-SHIFT Controller is preset from the factory to shift at high rpm (9990 1-2 shift). If you should rev engine up in neutral the solenoid on your shifting device will be activated if low rpms are set in the E-SHIFT, which may shift vehicle into gear. If you wish to test your shifting device at low rpm (**which are greater than your FallBack RPM**), **place car on jackstands**, place into first gear and bring engine rpm up slowly to verify shift point. If you have a MSD ignition tester, you can test the actual RPM's you set without starting your motor. Remember on three speed transmissions you must lead 1-2 shift rpm by about 300-500 rpm. Example: Set the CHEETAH E-SHIFT Controller to 6500 rpm if the desired shift point is 6800-7000 rpm. The 2-3 shift usually will shift exactly at what you set the controller rpm. Every car responds a little different.

Testing Your Controller Using a CHEETAH E-SHIFT Valve Body

Set low RPM's (**which are greater than your FallBack RPM**) into your controller and then in park, rev engine and watch the small yellow shift lights on the controller come on at the proper RPM's. If in doubt, take a volt meter and check each output to see if you get a 12-16 volt each time the proper RPM comes up. If you have a MSD ignition tester, you can test the actual RPM's you set. Remember on three speed transmissions you should lead 1-2 shift rpm by about 300-500 rpm. Example: Set the CHEETAH E-SHIFT Controller to 6500 rpm if the desired shift point is 6800-7000 rpm. The 2-3 shift usually will shift exactly at what you set the controller rpm. Every car responds a little different.

WILL NOT WORK PROPERLY WITH ODD FIRE V6!

TURBO ACTION

HIGH PERFORMANCE TRANSMISSIONS

1535 Owens Road, Jacksonville, FL 32218 ~ Phone 904-741-4850 ~ FAX 904-741-4853

www.turboaction.com

CHEETAH E-SHIFT Controller

Part #70600

4 Shift Output

CAUTION: Do Not connect directly to a Magneto ignition system. You must use an adapter available from Auto Meter, Race Pack, etc.

FIRST , READ INSTRUCTIONS CAREFULLY, THEN PROCEED TO INSTALL CONTROLLER BY FOLLOWING EACH STEP INDIVIDUALLY.

| | | | | |
|----------------------|---|---|----------|--|
| Controller | 1 | - | 70600 | Controller |
| Kit Includes: | 2 | - | U00780A | Screw Connector Terminals |
| | 1 | - | U00792-1 | Pit Road Switch, [Momentary On/Off (Normal) (For Use with CHEETAH E-Shift Valve Bodies Only) |
| | 1 | - | | Set of Instructions |
| | 2 | - | 50102 | Contingency Decals |

Warranty: Your unit from the date of purchase has a one full year factory warranty against factory defects, which includes hardware and software problems. It must be understood that the warranty will not cover any *CHEETAH E-SHIFT Controller* which has been wired improperly, including faulty current and voltage input or output connections! This warranty applies to the original owner only.

STEP #1: Pick a location for your *CHEETAH E-SHIFT Controller*. Do Not install in the Engine Compartment or within 12" of the Ignition Coil or it's High Output Wire.

STEP #2: Dedenbear, Biondo, Etc. Electric Shifters require a high current relay. The CO2/Electric Shifters normally do not. We suggest you use 14-16 gauge wire for all connections. If you are connecting to a device drawing more than 5 Amps, use a high current relay, Turbo Action Part #5000-1, between the *CHEETAH E-SHIFT Controller* and the device you wish to control. See special drawing for high current relay hook up.

NOTE: All *CHEETAH E-SHIFT Electronic Valve Bodies* require 5 Amps or less to operate. Please check with the manufacturer of your device on how much current it will draw before connection to our *CHEETAH E-SHIFT Controller*.

STEP #3: When wiring your Controller, be sure wires are trimmed with approximately 1/4" - 5/16" of wire showing. After trimming wire, twist wire tightly so there are no loose strands of wire.

CAUTION: If stray wires accidentally touch other wires, you will cause a short and burn up your Controller and or your RPM activated device.

STEP #4: It is suggested you fuse your Controller for an extra margin of safety. See Figure #1,#2,#3,#4 & #5 for proper connecting of your Controller.

STEP #5: The following information together with Fig. #1, #2, #3, #4 & #5 should make your wiring a simple task.

01/18/02, 02/13/02,4/16/03

Terminal Block Inputs (Reading Left to Right)

- Terminal #1 = Power Source 12-16V. **Must be connected to battery, no switch in between!**
- Terminal #2 = Ground for input power.
- Terminal #3 = Tachometer signal input from ignition system.
- Terminal #4 = 12-16V from Burnout/LineLock switch. Digital display reads, BURN when switch engaged.
- Terminal #5 = Use switch with *CHEETAH E-SHIFT Valve Bodies* only. Use the enclosed Pit Road (momentary) Switch to send 12-16V to this terminal. Switch only needs to be pushed and released. Digital display will read P. rd. This function will allow driving thru the pits at a lower RPM. This function also automatically disengages when: 1. Engine shuts off, 2. LineLock Switch engaged, or 3. Tranz Brake Switch Engaged. Note, use this terminal only for *CHEETAH Electronic Valve Bodies*.
- Terminal #6 = Apply 12-16V from Tranz Brake Switch, Clutch Switch or LineLock Switch (sticks only). Digital display will read HOLD when switch engaged.

Terminal Block Outputs/Input (Reading Right to Left)

- Terminal #1 = This is a **Input** to *CHEETAH E-SHIFT Controller* and is determined by the equipment you will control with the *CHEETAH E-SHIFT Controller*. If your shift light or air shifter requires a positive voltage 12-16V, you would connect 12-16 volts here. All *CHEETAH E-SHIFT Valve Bodies* require 12-16V here. If your shift light or air shifter needs a ground, then you will connect a ground here.
Note: We do not recommend the ground method! It is very dangerous!!
- Terminal #2 = Output for First Shift will be the same as the Terminal #1 when selected RPM is reached.
- Terminal #3 = Output for Second Shift will be the same as Terminal #1 when selected RPM is reached.
- Terminal #4 = Output for Third Shift will be the same as Terminal #1 when selected RPM is reached.
- Terminal #5 = Output for Fourth Shift will be the same as Terminal #1 when selected RPM is reached.

Features of the CHEETAH E-SHIFT Controller

- ◆ Will control most any RPM activated device:
 - Electronic valve bodies
 - Air or electric shifters
 - Shift lights
 - Ignition retards, throttle control, rev limiter
- ◆ Four outputs which can be 12-16 volts or ground
- ◆ Outputs can be either Holding or Pulsed
- ◆ Race Mode
- ◆ Three Controlling inputs:
 - Burnout Mode
 - Tranzbrake or Clutch Pedal Mode
 - Pit Road Mode
- ◆ Shifts can be made by RPM, Time or Combination of both
- ◆ No Early Upshifts or Double Shifts
 - Starting line to First shift time adjustment
 - Shift to shift time adjustment
- ◆ Tachometer Display
- ◆ Tamper Proof
- ◆ Virtual Memory (no battery backup needed)
- ◆ Engine cylinder selection 2,4,6,8,10
- ◆ Max RPM is 15,000
- ◆ All functions automatic
- ◆ All Factory Defaults Resettable
- ◆ Easy to Test
- ◆ Contingency Program (IHRA & NHRA)
- ◆ No shifts while in Tranz Brake Hold Mode

Standard Transmission Using Shift Lights

Stock and SuperStock rules require that the clutch be depressed for each shift. If you wire your clutch switch to the tranz brake input your *CHEETAH E-SHIFT Controller* will be erratic. We suggest you wire your linelock switch output to the tranz brake input. This way you still will have the timer function when you leave the line and will not be reactivating the hold function of the controller each time you depress the clutch. Also suggest setting your fall back RPM (Position #5) 4000-4500 RPM with a standard transmission or Lenco. If you do this, your engine between shifts should not fall below the FallBack RPM. *You must set all Race and Burnout shift points higher than Fall Back even if you do not use the Burnout mode. If you do not, "NO" will come up on your display. **Note:** You **cannot** hook the linelock switch to both the tranz brake input and the burnout input.

9/19/14

Figure #1

CHEETAH E-SHIFT Controller

#70600

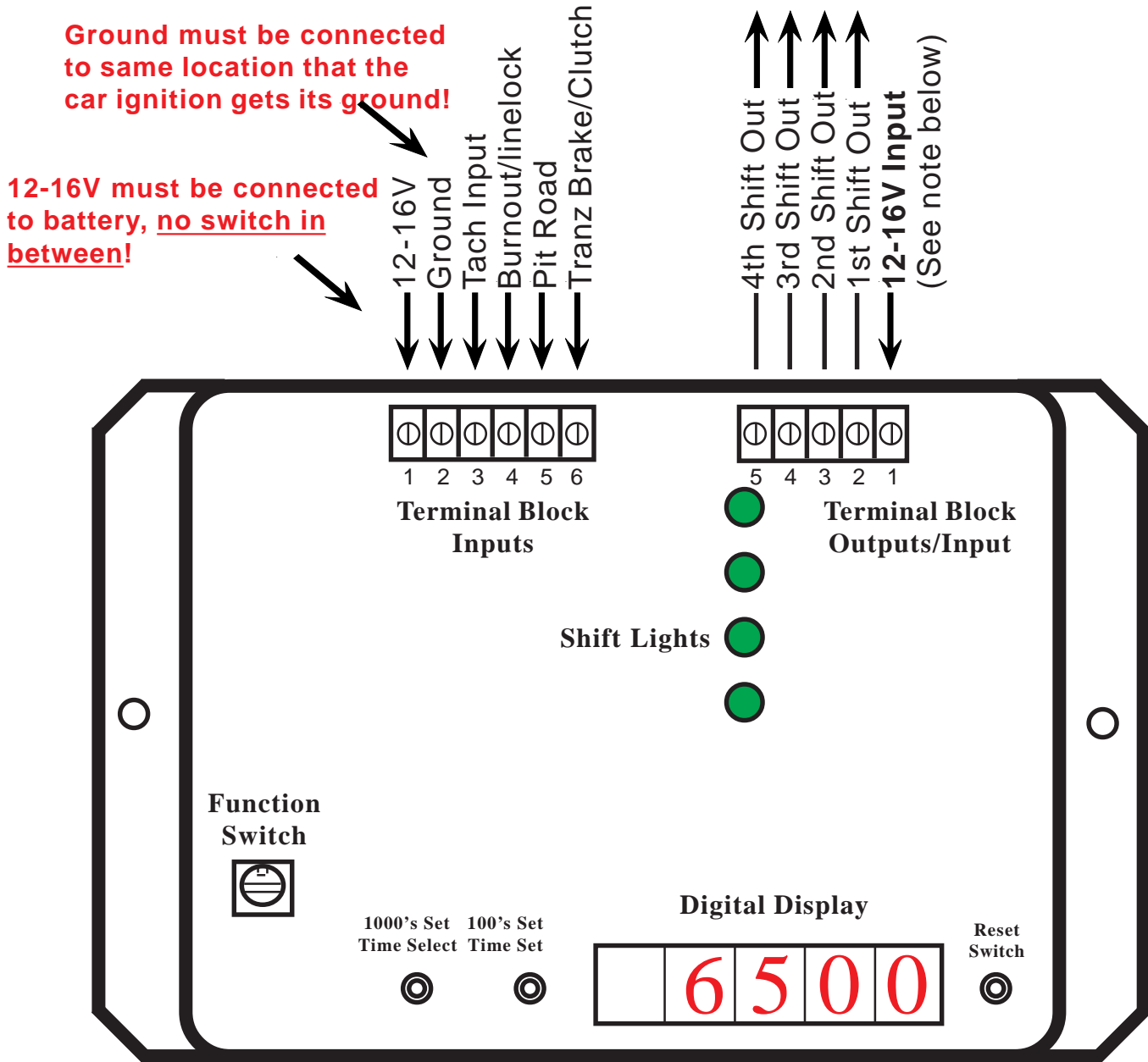

NOTE: The terminal block containing the 1-4 shift outputs also has one input which can be 12-16 Volts (**The preferred way to wire up shift devices.**) or a ground (**Dangerous way to wire shift devices.**) depending on the device you are trying to activate. This power source passes directly to the outputs when the controller activates the appropriate relay or relays. We suggest 12-16V power be supplied to the device from your *CHEETAH E-SHIFT Controller* and have your **solenoid or light grounded at its location**. Note: Some Electric Shifters such as Dedenbear, Biondo, Etc. require a high current relay Turbo Action Part #5000-1. See Fig. #4.

Figure #2

CHEETAH E-SHIFT Electronic Valve Bodies

or

Multiple Solenoid Applications Suggested Wiring for Terminal Blocks

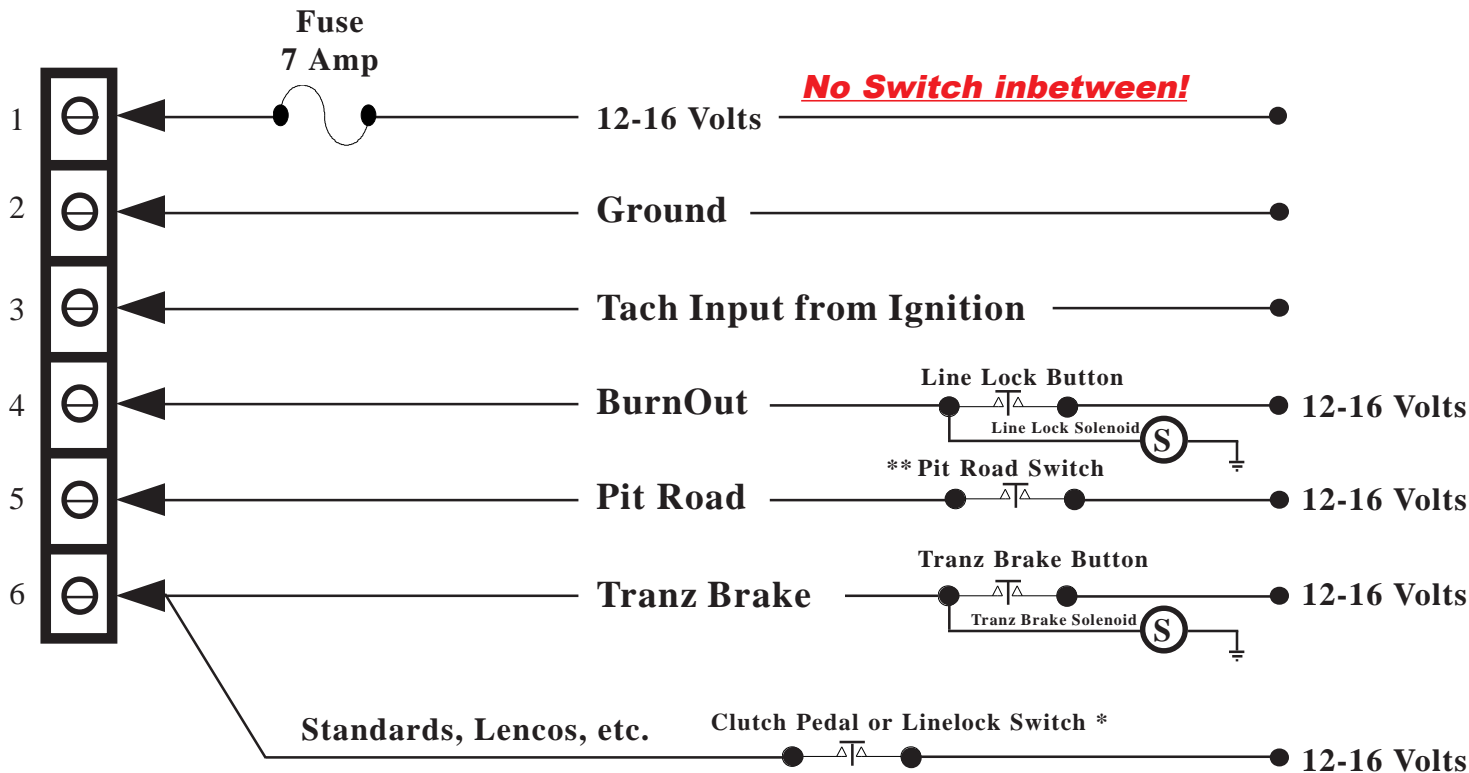

CHEETAH E-SHIFT Electronic Valve Bodies

or other Multiple Solenoid Application

Outputs connected to individual wires on multiple solenoid applications.

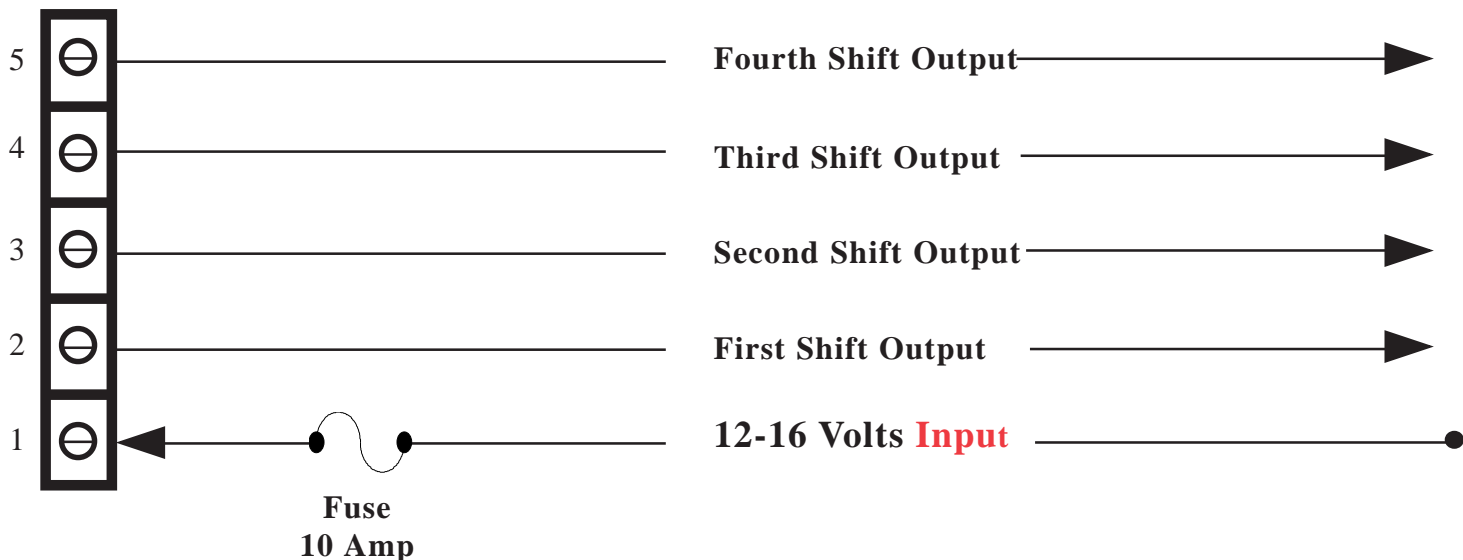

*See Page #4

**Only used with CHEETAH Electronic Valve Bodies

9/19/14

Figure #3

Shift Lights and Air Shifters

Suggested Wiring for Terminal Blocks

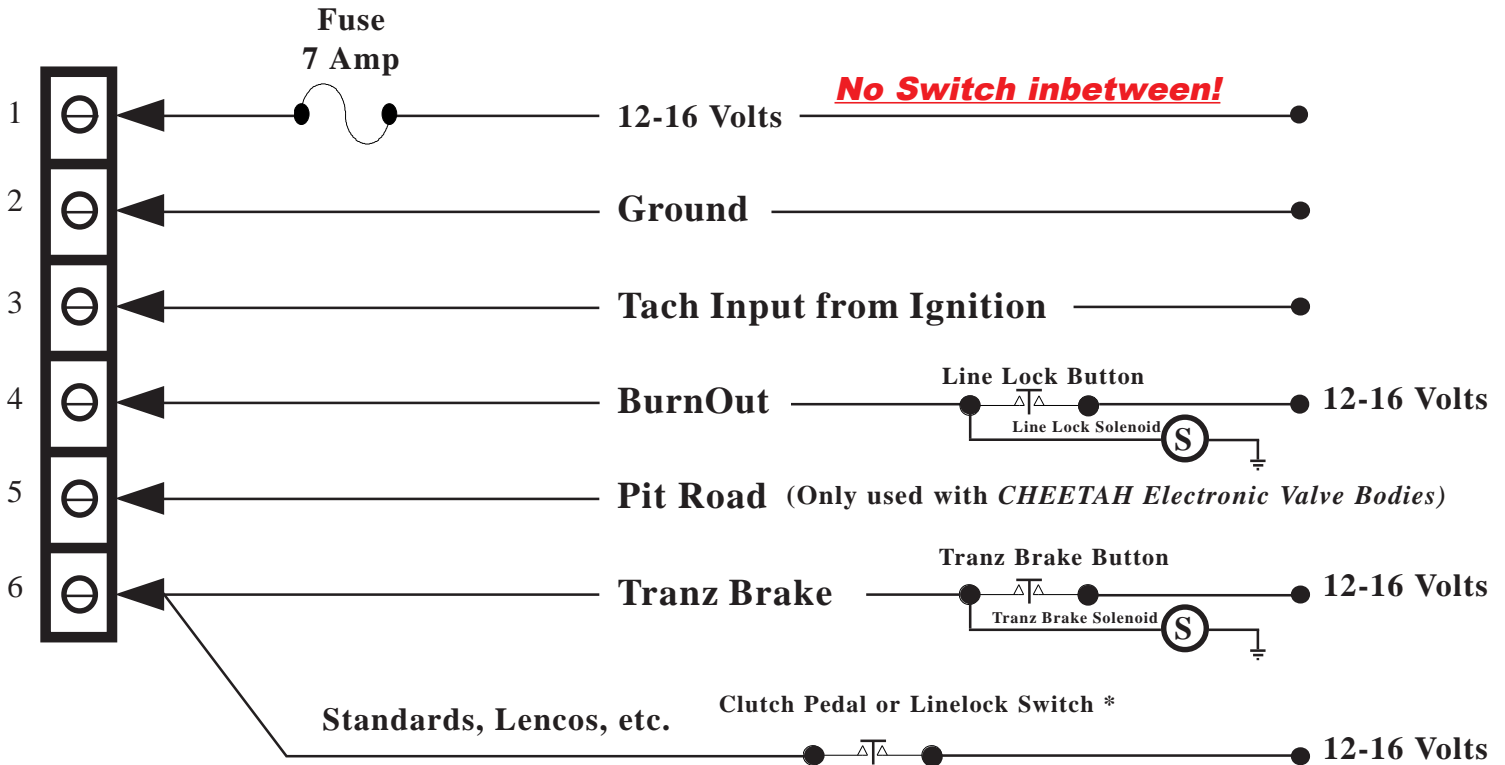

Shift Lights and Air Shifters

Tie the outputs together for only the number of shifts required.

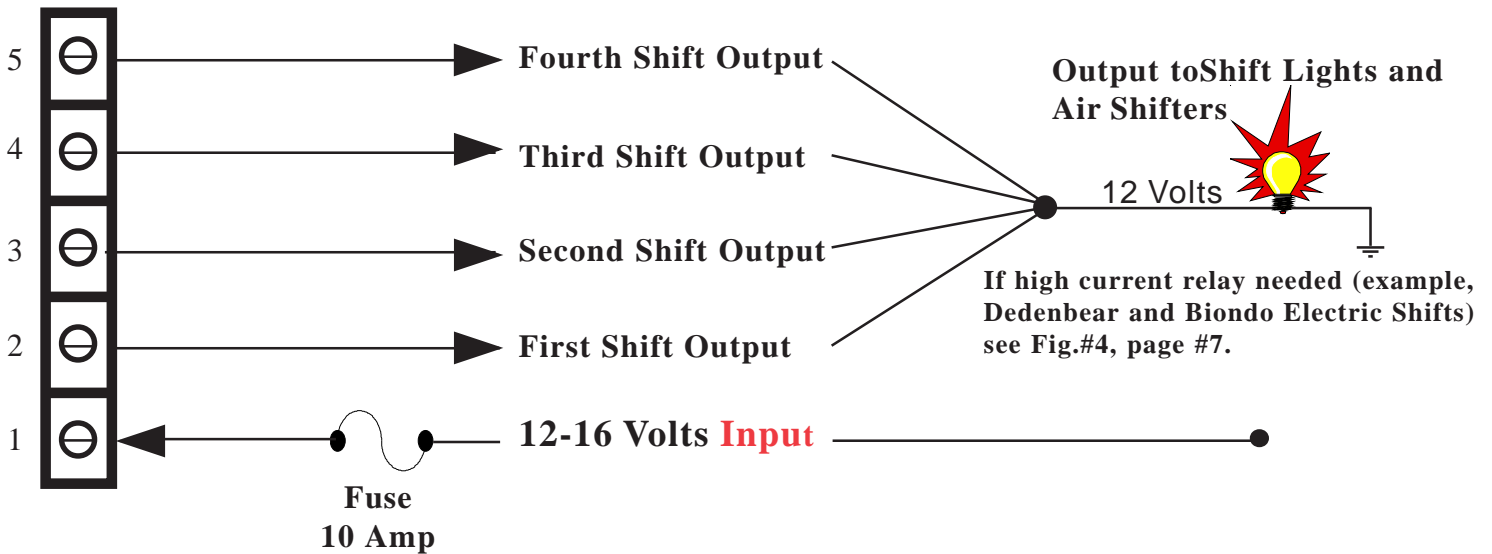

*See Page #4

NOTE: Air/C02/Electric Shifters
Be sure to Set Relay #5 to 0.2 at position #14.

Figure #4 Power Relay for High Current Devices Example: Dedenbear and Biondo Electric Shifters

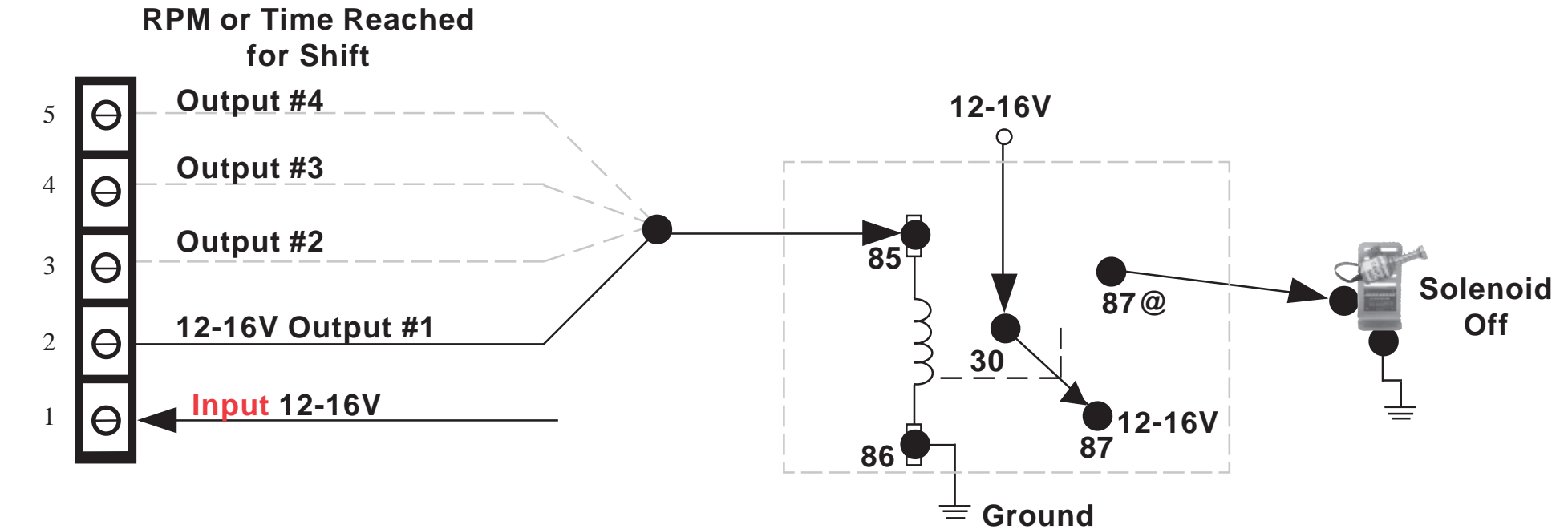
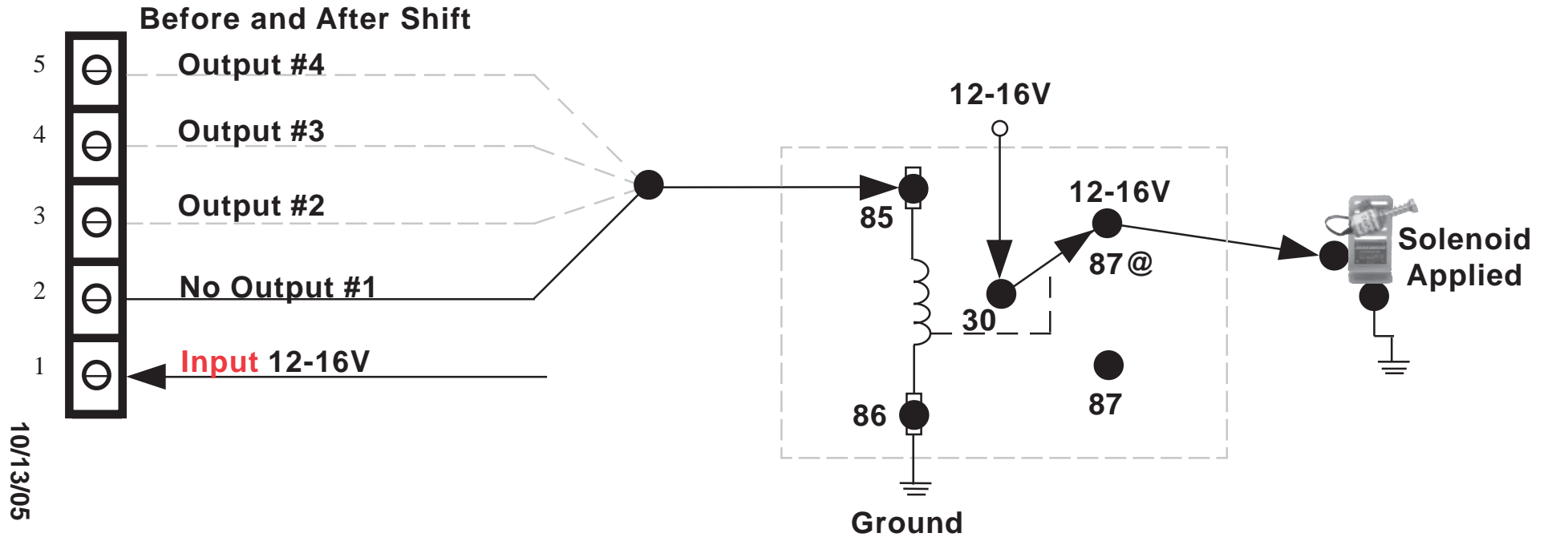
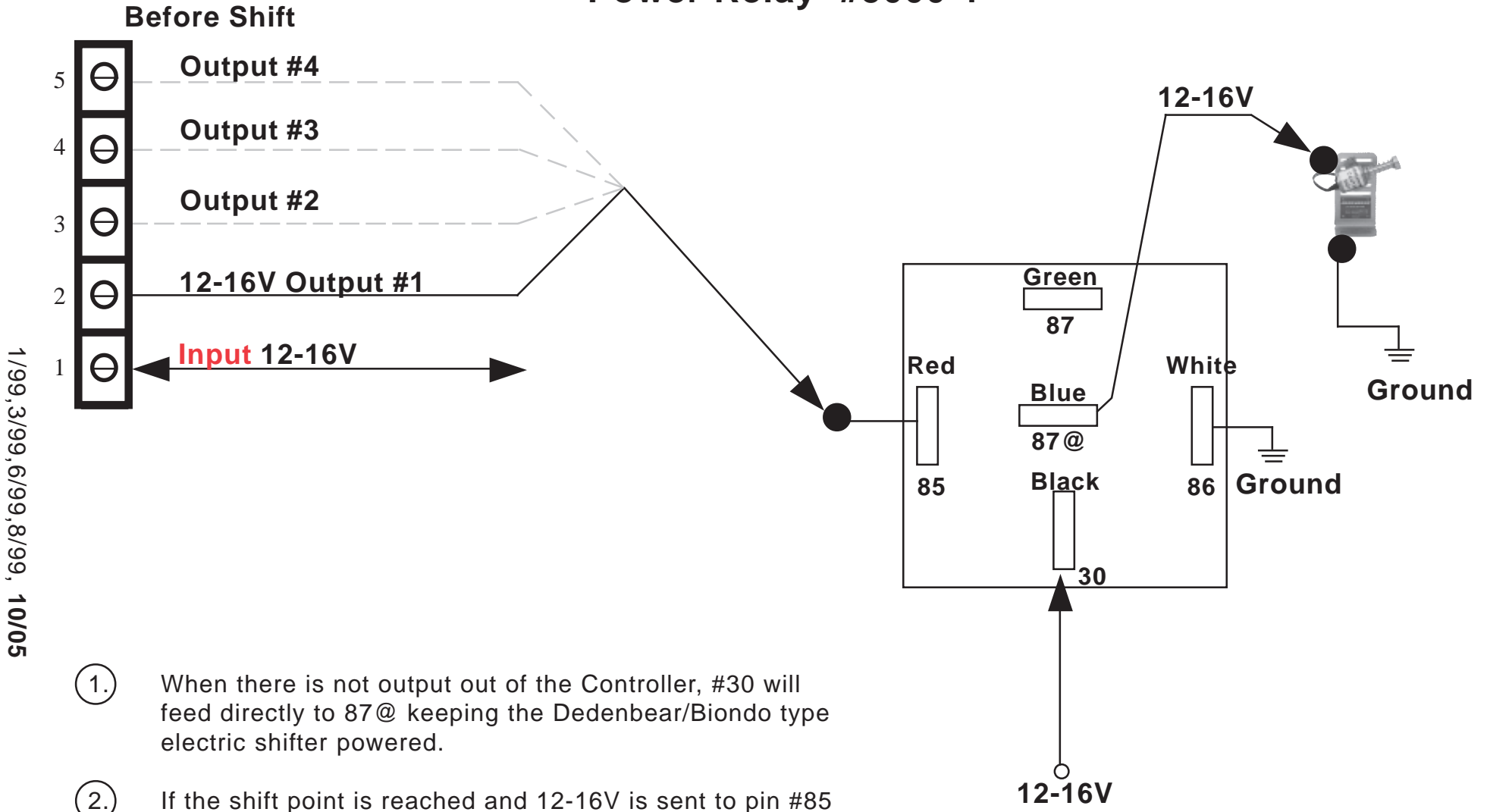

Figure #5 Power Relay #5000-1



1/99, 3/99, 6/99, 8/99, 10/05

- ①. When there is not output out of the Controller, #30 will feed directly to 87@ keeping the Dedenbear/Biondo type electric shifter powered.
- ②. If the shift point is reached and 12-16V is sent to pin #85 the output of pin #30 will no longer go out to #87@ to power the electric shifter solenoid, but instead will be waiting at pin #87, which is not being used. This will cause the spring to push the ram and shift the shifter.

TURBO ACTION

CHEETAH E-SHIFT Controller Programming for 4 Shifts

Your unit has been shipped with specific factory defaults which are changeable by you.

Programming Function Switch Positions 1 -15:

Turn power on to your *CHEETAH E-SHIFT Controller*, but **do not** start engine.

POSITION #0: Normal Running

- Race Mode - Display reads **Engine RPM**
- Burn Out Mode - Display reads **Burn**
- Pit Road Mode - Display reads **P._rd**
- Hold Mode - Display reads **Hold**

POSITION #1: Race First (1-2) Shift RPM

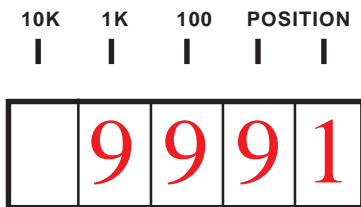

Fig. #1

Turn **Function Switch** knob clockwise one increment, until the right LED position display reads **1**. This position sets the **Race First Shift RPM** to within 100 RPM Fig. #1. *Note: This shift needs to be 200-300 RPM early on 3, 4 and 5 speed transmissions.*

Factory Default = 9990 RPM (Fig. #1).

Program Position #1:

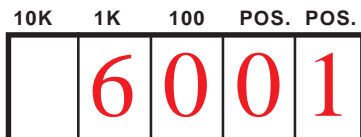

Fig. #2
6000 RPM

- a. **Push Reset Button:** Display will read position number only.
- b. **To set 1000 RPM's:** Push **1000's Button** till it reads 1-15 (1000-15000 RPM).

EXAMPLE: If you stop at the #6, it will read as shown in Fig. #2.

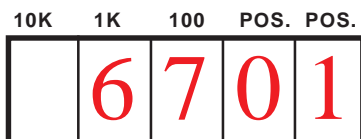

Fig. #3
6700 RPM

- c. **To set 100 RPM's:** Push **100's Button** till it reads 0-9 (000-900 RPM).

EXAMPLE: If you stop at the #7, it will read as shown in Fig. #3.

POSITION #2: Race Second (2-3) Shift RPM

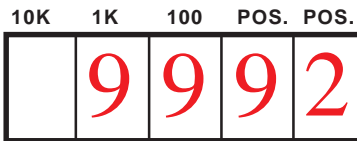

Fig. #4

Turn **Function Switch** knob clockwise until the right LED display position reads 2. This position sets the **Race Second Shift RPM** to within 100 RPM Fig. #4.

Factory Default = 9990 RPM (Fig. #4)

Program Position #2:

Do the same as Position #1.

POSITION #3: Race Third (3-4) Shift RPM

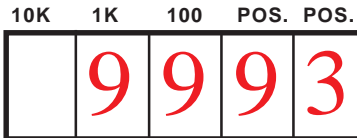

Fig. #5
5000 RPM

Turn **Function Switch** knob clockwise until the right LED display position reads 3. This position sets the **Race Third Shift RPM** to within 100 RPM Fig. #5.

Factory Default = 9990 RPM (Fig. #5)

Program Position #3:

Do the same as Position #1.

POSITION #4: Race Fourth (4-5) Shift RPM

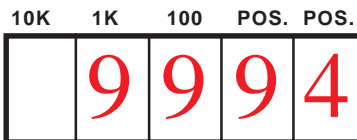

Fig. #6
5500 RPM

Turn **Function Switch** knob clockwise until the right LED display position reads 4. This position sets the **Race Fourth Shift RPM** to within 100 RPM Fig. #6.

Factory Default = 9990 RPM (Fig. #6)

Program Position #4:

Do the same as Position #1.

POSITION #5: Race/BurnOut FallBack Shift RPM

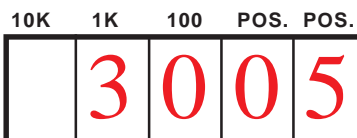

Fig. #7
3000 RPM

Turn **Function Switch** knob clockwise until the right LED display position reads 5. This position sets the **Race/BurnOut FallBack RPM**, which is the RPM that the controller resets on engine deceleration Fig. #7.

Factory Default = 3000 RPM (Fig. #7)

We suggest not changing this setting till you try in vehicle.*All RPM's position 1,2,3,4,6,7,8 & 9 must be higher than this RPM or display will read "NO". If this happens change position in error. Shut power off to Controller, then back on.

Program Position #5:

Do the same as Position #1.

POSITION #6: BurnOut First (1-2) Shift RPM

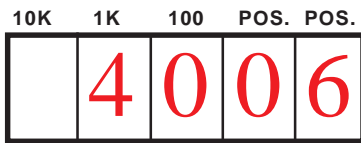

Fig. #8
4000 RPM

Turn **Function Switch** knob clockwise until the right LED display position reads 6. This position sets the **BurnOut First Shift RPM** to within 100 RPM Fig #8.

Factory Default = 4000 RPM (Fig. #8)

Program Position #6:

Do the same as Position #1.

POSITION #7: BurnOut Second (2-3) Shift RPM

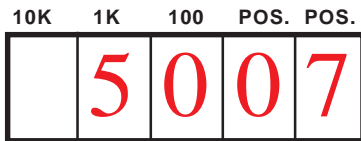

Fig. #9
5000 RPM

Turn **Function Switch** knob clockwise until the right LED display position reads 7. This position sets the **BurnOut Second Shift RPM** to within 100 RPM Fig. #9.

Factory Default = 5000 RPM (Fig. #9)

Program Position #7:

Do the same as Position #1.

POSITION #8: BurnOut Third (3-4) Shift RPM

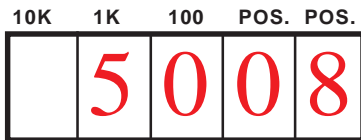

Fig. #10
5000 RPM

Turn **Function Switch** knob clockwise until the right LED display position reads 8. This position sets the **BurnOut Third Shift RPM** to within 100 RPM Fig. #10.

Factory Default = 5000 RPM (Fig. #10)

Program Position #8:

Do the same as Position #1.

POSITION #9: BurnOut Fourth (4-5) Shift RPM

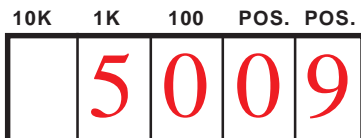

Fig. #11
5000 RPM

Turn **Function Switch** knob clockwise until the right LED display position reads 9. This position sets the **BurnOut Fourth Shift RPM** to within 100 RPM Fig. #11.

Factory Default = 5000 RPM (Fig. #11)

Program Position #9:

Do the same as Position #1.

Position #10, #11 and #12 for *CHEETAH Electronic Valve Bodies Only.*

POSITION #10: Pit Road First (1-2) Shift RPM

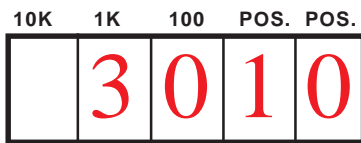

Fig. #12
3000 RPM

Turn **Function Switch** knob clockwise until the right LED display position digits read 10. This position sets the **Pit Road First Shift RPM** to within 100 RPM Fig. #12.

Factory Default = 3000 RPM (Fig. #12)

Program Position #10:

Do the same as Position #1.

POSITION #11: Pit Road Second (2-3) Shift RPM

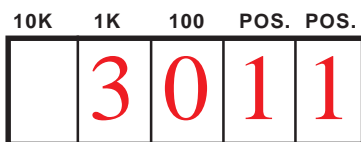

Fig. #13
3000 RPM

Turn **Function Switch** knob clockwise until the right LED display position digits read 11. This position sets the **Pit Road Second Shift RPM** to within 100 RPM Fig. #13.

Factory Default = 3000 RPM (Fig. #13)

Program Position #11:

Do the same as Position #1.

POSITION #12: Pit Road FallBack RPM

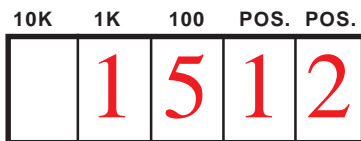

Fig. #14
1500 RPM

Turn **Function Switch** knob clockwise until the right LED display position digits read 12. This position sets the **Pit Road FallBack RPM**, which is the RPM that the controller resets on engine deceleration Fig. #14.

Factory Default = 1500 RPM (Fig. #14)

Program Position #12:

Do the same as Position #1.

POSITION #13: Number of Cylinders

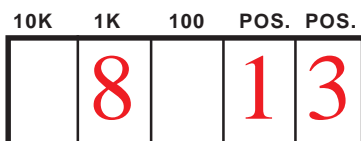

Fig. #15
8 Cylinders

Turn **Function Switch** knob clockwise until the right LED display position digits read 13. This position sets the **Number of Cylinders 2, 4, 6, 8 or 10** Fig. #15.

Factory Default = 8 Cylinders (Fig. #15)

Program Position #13:

Push either **1000's** or **100's Button** to advance the number of cylinders.

POSITION #14: Shift Time Adjustment

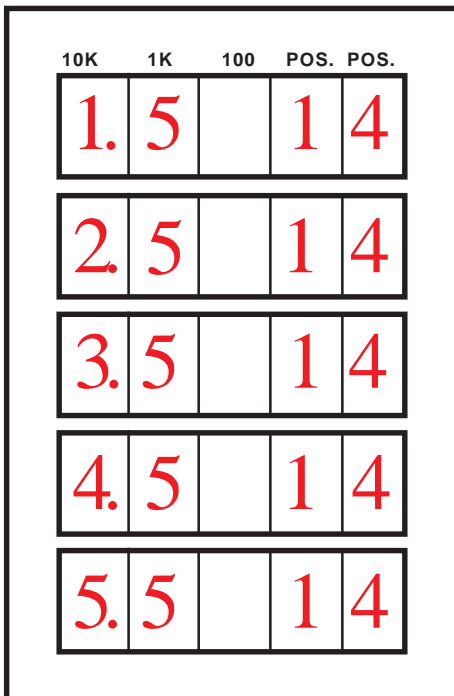

Fig. #16

NOTE

Vehicles using Air/C02/
Electric Shifters-suggest
setting #5 Relay to 0.2 -
Leave the other relays at 0.5

Turn **Function Switch** knob clockwise until the right LED display position digits read **14**. The **Time Select** position (10K position on the display) is capable of setting the following time functions:

- 1 = Sets the time between when you leave the starting line and the first shift. Must use the Hold function (tranzbrake or clutch pedal to activate this timer). (0.1 - 0.9 second).
- 2 = Sets time between the 2-3 shift. (0.1 - 0.9 sec.).
- 3 = Sets time between the 3-4 shift. (0.1 - 0.9 sec.).
- 4 = Sets time between the 4-5 shift. (0.1 - 0.9 sec.).
- 5 = Sets time that the relays in the controller hold, when activated in the **Pulsing mode**. See **Position #15** for explanation of **Holding** or **Pulsing Relays**. This allows you to adjust the length of time your shift light or air shifter stays on, or pulses (0.1 - 0.9 sec.).

Setting these times will prevent early upshifts or double shifts. Each of the five times can be set from 0.1- 0.9 of a second in duration.

Factory Default = 0.5 sec (Fig. #16)

We suggest not changing these settings till you try in vehicle.

Program Position #14:

The **10K** LED to the far left will read 1-5. The number represents one of five **Time Select Functions** listed above. The **1K** LED position represents the **Time Set** in 0.1 second increments.

To Set Time Select Function Position:

Push **1000's Button** to advance from 1-5.

To Set Time Set For Each Time Select Function:

Push **100's Button** to advance from 0.1 - 0.9 second.

Repeat steps above for each time function you wish to change.

3/31/04

POSITION #15: Controller Relays

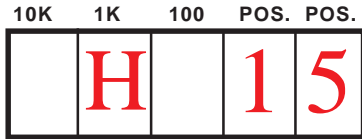

Fig. #17

Turn **Function Switch** knob clockwise until the right LED display position digits read **15**. This position sets relays to **Holding Relays (H)** or **Pulsing Relays (P)**. Also, **Factory Reset** for all defaults can be set in this position Fig. #17.

Factory Default = H (Fig. #17)

Program Position #15:

Push either the **1000's** or the **100's Button**, it will cycle between **H & P**.

Note: Turbo Action *CHEETAH E-SHIFT* Electronic Valve Bodies require **Holding Relays**. **Shift Lights and Air or Electric Shifters** require **Pulsing Relays**.

Restore Factory Defaults:
Set **Function Switch** to Position #15 and press **Reset Button** for 5 seconds.

Turn to #0 position after making your changes.

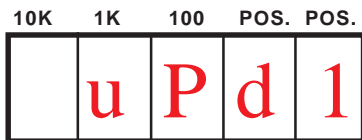

Fig. #18

Position #0, UPDATE Function

After any change to positions 1-15 your controller will update all new entries.

Display will read **uPd1** then **uPd2** until it is finished updating (Fig. #18)

Display will go back to "0" when complete.

NOTE: Position #0 will read RPM of the engine if in the race mode. Depending on how many cylinders your engine has, a minimum engine RPM required to produce a readout.

Minimum RPM per number of cylinders:

| <u>Cylinders</u> | <u>RPM Minimum for a Display</u> |
|------------------|----------------------------------|
| 2 | 1500 |
| 4 | 750 |
| 6 | 500 |
| 8 | 370 |
| 10 | 300 |

January 15, 2009

Shifting Air Shifters or Electronic Valve Bodies with Time and RPM Combined.

#70600 CHEETAH E-SHIFT Controller Timer Settings for Comp and SuperStock Eliminators

Why use timers & RPM for your 1-2 shift?

The last 3-5 years high rpm engines, high stall converters, slow shift transmissions, lower rear gears and marginal traction all cause issues for accurate 1-2 shifts. The Turbo Action CHEETAH E-SHIFT Controller can eliminate most of these issues. CHEETAH E-SHIFT can delay your shift and then let rpm take over. This combination will make possible nearly perfect shifts every run.

The following will outline how to use our CHEETAH E-SHIFT to accomplish the near perfect every run:

1. You will need to wire your box slightly different than as shown in the wiring diagrams included with CHEETAH E-SHIFT Controller.
2. Go to Page 5, Figure #1 of the instructions. If you were using RPM only to shift, you would have your 1-2 SHIFT wire on 1st Shift Out and the 2-3 Shift wire on 2nd Shift Out.
3. Shifting with Time & RPM you must move the 1-2 SHIFT wire to the 2nd Shift Out position. Then move the 2-3 Shift wire to the 3rd Shift Out position.
4. Now you will change the RPM Settings in the CHEETAH E-SHIFT Controller.
5. Rotate the Function Switch to Position #1 and set RPM to 5000 RPM.
6. Rotate the Function Switch to Position #2 and set RPM to 5000 RPM.
7. Rotate the Function Switch to Position #14 to set Timers. Before setting them you need to look at your computer runs and find a good run and see at what time the shift occurred after leaving the starting line. Usually the time is 1.2-1.6 sec. Note your computer is telling you when the shift occurred not when the transmission was told to shift. Normally a transmission can take about 0.05 sec to shift.
8. If you determine the shift occurred at 1.4 sec, then you need to cause the shift to start before that time. Try 1.2 sec the first time. **It is better to be early than late!**
9. How to cause the shift to happen at approximately 1.4 sec:
 - a. At Position #14 you should be reading 1.5 (Relay 1, 0.5 sec delay). The 1000 Set Button is the Timer Select Button and the 100 Set Button is the Time Button when at Position #14. Time can only be set in tenths of a second.
 - b. Timer 1, Set Time to .9 by pushing 100 Set Button (1.9).
 - c. Timer 2, Push 1000 Set Button once to read 2.
 - d. Timer 2, Set Time to .3 by pushing 100 Set Button (2.3).
 - e. Do **not** change Timer 3 or 4.
10. The combination of Timer 1 (.9 sec) + Timer 2 (.3 sec) = 1.2 sec. When the timer finishes, RPM takes over and you told it to shift at 5000 RPM on both the #1 & #2 Function Positions. When your Timers time out, you are higher than 5000 RPM and the transmission shift cycle begins. Adjusting Timer 1 & 2 can do fine-tuning of your shift points.
11. Setting the 2-3 shift point, you will set Function Switch Position #3 and set to desired RPM (Example 9500 RPM, note LED's read 9503. The 3 in 9503 is the position you are at on the Select Rotary Switch.
12. Two more things must be done to complete this set up.
 - a. Connect 12-16 volts from a source such as a Clutch Pedal, Tranz Brake or Special switch on the tranz brake solenoid side, etc to Tranz Brake Position on the CHEETAH E-SHIFT Controller.
 - b. Connect 12-16 volts wire from solenoid side of Burnout Switch to Burn Position on the CHEETAH E-SHIFT Controller.
 - c. Set RPM to 9000 RPM at Function Positions #6, #7 and #8.

This completes the set up and should be ready to race.